

# owner's manual

Metagenics Fitness Inc.  
Compact 3D Smith machine

PK121A

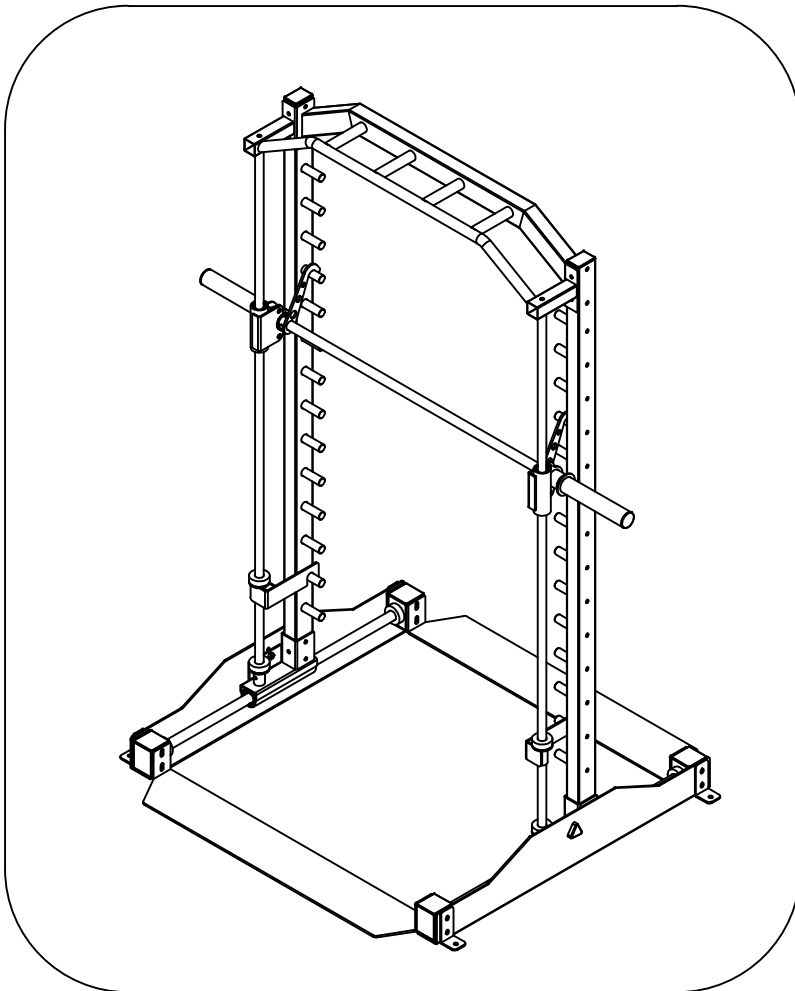

## Important Safety Information

Prior to assembly, remove components from the box and verify that all the listed parts were supplied.

NOTE: Hand tighten bolts and nylon until machine is fully assembled.

### ! CAUTION

Read all precautions and instructions in this manual before using this equipment.

### WARNING!

Before using this unit or starting any exercise program, consult your physician. This is especially important for persons over the age of 35 and/or persons with pre-existing health problems. The product LP assumes no responsibility for personal injury or property damage sustained by or through the use of this product.











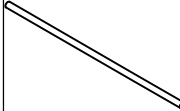

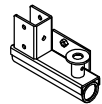
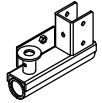
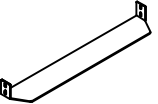

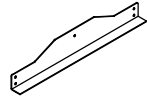
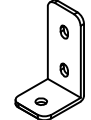
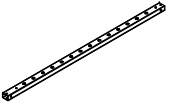

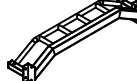
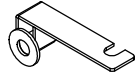
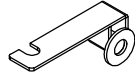



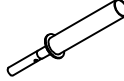

It is the owner's responsibility to ensure that all users of this unit have read the owner's manual and are familiar with safety information and precautions.

## SAFETY PRECAUTIONS





- This unit should only be used on a level surface and is intended for indoor use only. We recommend an equipment mat be placed under the unit to protect the floor or carpet and for easier cleaning.
- Wear comfortable, good-quality walking or running shoes and appropriate clothing. Do not use this unit with bare feet, sandals, socks or stockings!
- Always examine your unit before using to ensure all parts are in working order.
- Do not leave children unsupervised near to the unit.



# Part List

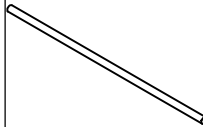

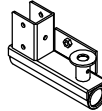
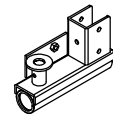

A 2PCS 	B 4PCS 	C Large buffer pad 4PCS 	CL 1PCS 	CR 1PCS 
D 2PCS 	E 4PCS 	F 2PCS 	G 4PCS 	H 2PCS 
I 2PCS 	J 1PCS 	KL 1PCS 	KR 1PCS 	L small buffer pad 4件 
S 2PCS 	M 28PCS 	N 1PCS 	O 2PCS 	P barrel 2PCS 
1 M10*110 Bolt,Nut,Washer 8PCS 	2 M10*75 Bolt,Nut,Washer 4PCS 	3 M10*90 Bolt,Nut,Washer 6PCS 	4 M8*45 Bolt,Nut,Washer 2PCS 	5 M10*20 Bolt,Washer 30PCS 
6 M10*70 Bolt,Nut,Washer 4PCS 	7 M12*25 Bolt,Nut,Washer 4PCS 	8 M8 Expansion screws 4PCS 	9 M10*30 screws 2PCS 	10 M10*15 Bolt 2PCS 

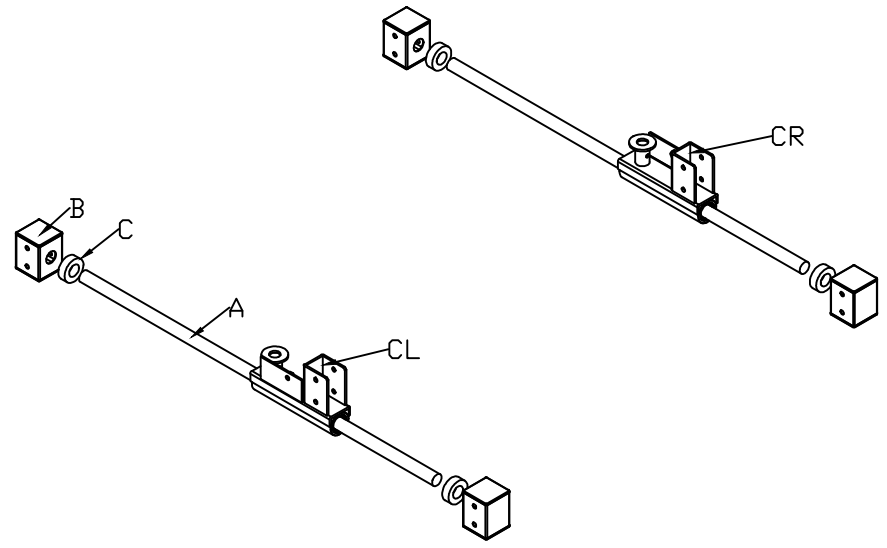
# Step 1

A 2PCS 	B 4PCS 	CL 1PCS 	CR 1PCS 
C Large buffer pad 4PCS 			

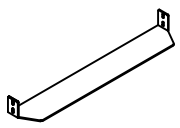
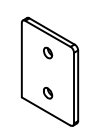
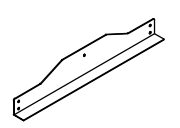
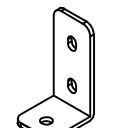

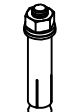



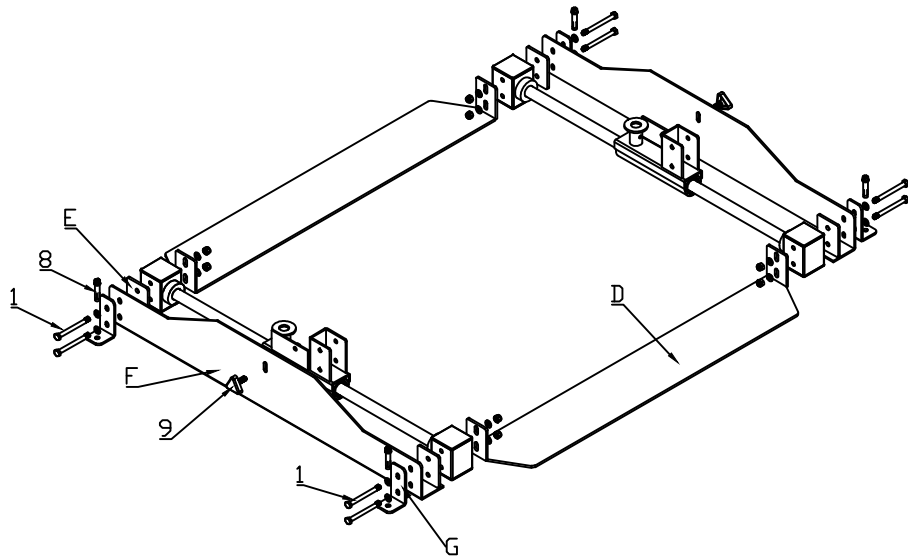

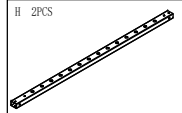

# Step 2

D 2PCS 	E 4PCS 	F 2PCS 	G 4PCS 
1 M10*110 Bolt,Nut,Washer 8PCS 	8 M8 Expansion screws 4PCS 	9 M10*30 screws 2PCS 	

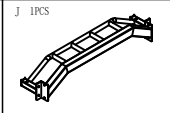
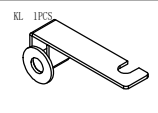
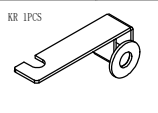

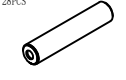
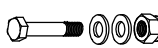
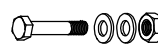
— 3 —



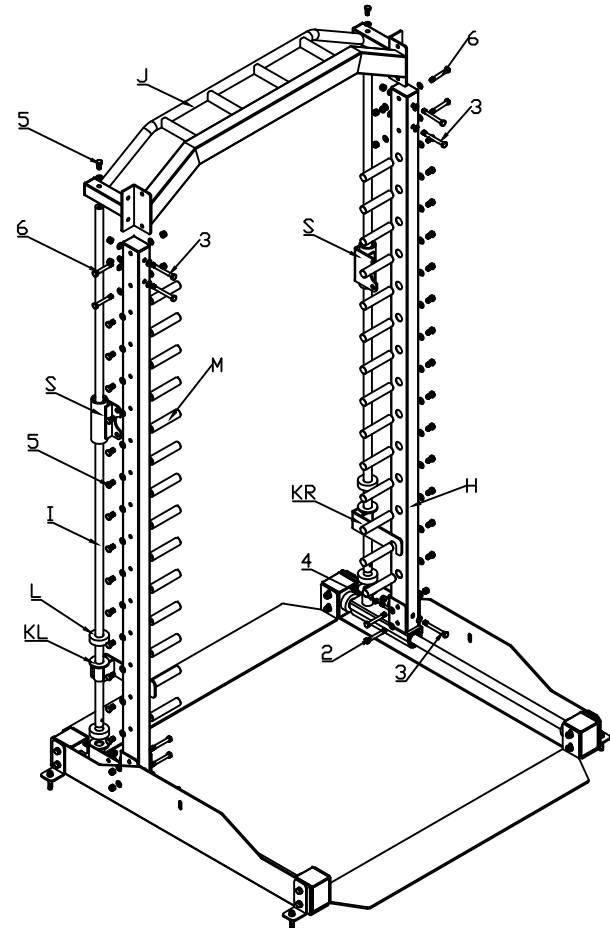

# Step 3

H 2PCS 	I 2PCS 	J 1PCS 	KL 1PCS 	KR 1PCS 
L small buffer pad 4PCS 	S 2PCS 	W 28PCS 	2 M10*75 Bolt,Nut,Washer 4PCS 	3 M10*90 Bolt,Nut,Washer 6PCS 
4 M8*45 Bolt,Nut,Washer 2PCS 	5 M10*20 Bolt,Washer 30PCS 	6 M10*70 Bolt,Nut,Washer 4PCS 		



— 4 —

# Step 4

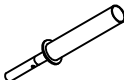
7 M12*28Bolt, Nut, Washer 4PCS 	N 1PCS 	O 2PCS 	10 M10*15 Bolt 2PCS 	P barrel 2PCS 
---	---	---	--	---

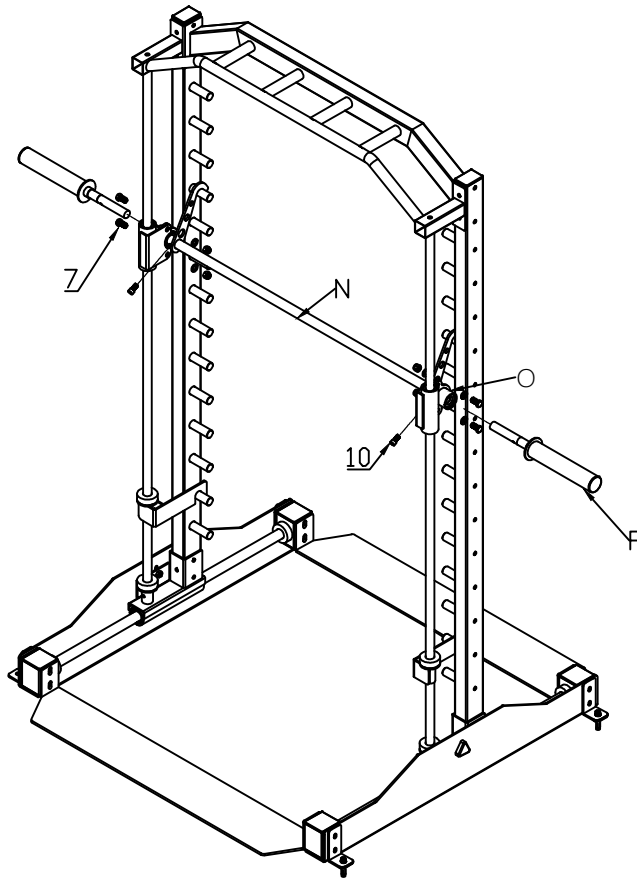

## General Safety Rules

There is a risk taken by all individuals who use this type of equipment. To reduce risk, you must follow these rules:

1. Inspect equipment before each workout. Check that all nuts, bolts, screws and pop pins are in place and fully tightened. Also, before use, check cables for signs of wear. Replace all worn parts immediately. Never use machine if any parts are damaged or missing. FAILURE TO FOLLOW THESE RULES MAY RESULT IN EXTREMELY SERIOUS INJURY.
2. Keep clear of cables and all moving parts when the machine is in use.
3. Always make sure all links are closed when doing any cable/pulley/strap exercises.
4. Exercise with care. Perform your exercises at a smooth constant pace; never perform jerky or uncoordinated movements that can cause injury.
5. It is recommended that you perform your workouts with a training partner.
6. Do not allow children or minors to play on or around this equipment.
7. Consult your physician before starting your exercise program.

### For your own safety, do not begin any exercise program without proper instruction.

Routine inspection and maintenance is of importance to ensure maximum safety and performance. We use the highest quality materials available, but wear is inevitable and unavoidable. Therefore, you must carefully inspect your equipment as outlined in the Maintenance Schedule. Be advised that dangerous conditions can arise even during a warranty period. A warranty does not negate the owner's responsibility to thoroughly, carefully and daily inspect the machine.

Including maintaining the equipment the owner's responsibility is also to:

1. Always provide adequate supervision to all end-users.
  2. Instruct all end-users of proper usage.
  3. Be sure all supervisors and personal trainers who instruct end-users on equipment use are properly trained and know the function and importance of every adjustment and setting.
- Also, be sure these trainers provide proper instruction to end-users on the fundamentals of strength training.

### Cables

1. While the machine is not in use. Carefully run your fingers along the cable to feel for thinning or bulging areas. Replace cables immediately at the first sign of damage or wear. Do not use equipment until damaged cable has been replaced.
2. Visually inspect the cables for fraying, cracking, peeling or discoloration.
3. Check slack in cables and re-adjust cable tension if needed.
4. Check that the jam nut on the selector rod top bolt is tight.

### Upholstery

1. Wipe down after every workout.
2. Periodically take the time to use a mild soap or a mild vinyl upholstery cleaner. Avoid using any abrasive cleaner not intended for use on vinyl.
3. Keep sharp or pointed objects out of your pockets and clear of all upholstery.

### Nuts/Bolts/Fasteners

1. Periodically inspect all nuts and bolts. Tighten if needed. If bolts seem to loosen periodically.
2. Go through a re-tightening sequence periodically to ensure that all hardware is properly tensioned.

### Guide Rods

Wipe clean with a dust free rag. Lubricate with a Silicon or Teflon based lubricant.

### Adjustments / Locking Pins / Tightening Knobs

1. Check all pieces for signs of visible wear or damage.
2. Check springs in Snap Links and Pop Pins for proper tension and alignment.
3. If the spring sticks or has lost its rigidity, replace it immediately.

### Anti-Slip Surfaces

Replace if they appear worn or become slippery.